

# The Message

The Newsletter of  
Trinity Episcopal Cathedral - Little Rock, Arkansas

A House of Prayer for All People

Lent 2023



## Inside

The Very Rev. Amy Dafler Meaux  
The Rev. Canon Dr. Lisa Corry  
Storybook Project

From the Choir Stalls  
Upcoming Youth Programs  
Summer Camp



## Facing our End

by The Very Rev. Amy Dafler Meaux

“...our mortal nature...”

Here is a phrase taken directly from the Ash Wednesday liturgy. “On this day, we remember that we are mortal, made from dust and to dust we shall return.”

What is it like to face our mortality? There is a 100% chance that we will all die. How does that make us feel? What do we think about death and dying?

When I began discerning the priesthood, one of my mentors encouraged me to consider the Burial liturgy in the prayer book. He said to me, “The Episcopal liturgy for burial is the best in Christendom. It will help you begin to shape your theology for understanding death and dying.” At the time, I had yet to bury or grieve anyone I loved intimately. He was trying to give me a solid, theological foundation for when those moments would come.

This Lent, I offer you an invitation to consider your mortality. I do not mean to be a grim reaper. Instead, I hope this is an opportunity for you to practice your

vulnerability muscles. When we face our mortality, we are set free to live our lives to the fullest, to be fully human.

Our faith is clear: death is not the end of our lives. When we die, we are raised from the dead, just as Jesus was raised. We have confidence and hope because we know death is not the end of our story. Of course, we grieve those who die, especially those who die young or tragically. Love and grief go hand and hand; we cannot have one without the other. And, the more we recognize—even celebrate—our vulnerability, the greater love we share with one another. This love, rooted in Christ’s love for us, is an assurance and manifestation of God’s activity in our lives and the world. The anthem for burial reads, “For if we have life, we are alive in the Lord, and if we die, we die in the Lord. So, then, whether we live or die, we are the Lord’s possession.” Because of love we belong to God in life and in death. Thanks be to God!

### Contemplating a Good Ending

- Take some time this season and read over the Burial liturgy (BCP pg. 491). What do you notice? How does this liturgy inform your faith?
- Join me for a Sunday morning series “Tying Up Loose Ends.” Over five weeks in Lent, we will consider the administrative realities of death: planning a funeral, caring for your financial legacy, and being intentional about your spiritual legacy. We’ll meet in Morrison Hall from 9:15 a.m. - 10 a.m.
- There are some wonderful memoirs that engage the realities of death and dying. Consider reading: “Being Mortal” by Atul Gawande, “When Breath Becomes Air” by Paul Kalanithi, or “No Cure for Being Human” by Kate Bowler.



## Creating a Relationship with God

by The Rev. Canon Dr. Lisa Corry

Lent brings many different things to mind. In the history of the church Lent was a practice tied to preparation for baptism. It involved personal reflection, fasting, penitence, and prayer, because it was thought that the decision to follow God demanded wholistic involvement: physical, mental, emotional, and spiritual. It is likely that from this historic practice comes the belief that one should wait until baptism to participate in communion.

It can be an interesting exercise to compare our history, tradition, and reasoning, in concern to faith, to the scriptures, and Jesus' life and teaching. Sometimes our beliefs and practices align well and sometimes not so well. It leads me to wonder what God thinks of Lent.

As we enter our Lent practice, it is important to remember that our relationship with God is not based on earning or merit. We cannot earn anything from God because our relationship is based on grace and rests in unending love.

So, what does Lent, the six weeks preceding the anniversary of Jesus' death, mean to us today? In our Christmas and Epiphany seasons we witness that our God is a God of love, revelation, and relationship. During Epiphany, Jesus, the personification of God, performs acts of healing and liberation, and teaches the importance of cultivating meaningful relationships and building up the kingdom of God. It is this helpful, loving, eye-opening aspect of God that we take with us into the season of Lent.

We begin Lent on Ash Wednesday with the imposition of ashes as a token of humiliation and sorrow for sin as illustrated throughout scripture. The liturgy for this day begins with a summary of our historical Lenten practices and ends with this invitation:

I invite you, therefore, in the name of the Church, to the observance of a holy Lent, by self-examination and repentance; by prayer, fasting, and self-denial; and by reading and meditating on God's holy Word. And, to make a right beginning of repentance, and as a mark of our mortal nature, let us now kneel before the Lord, our maker and redeemer  
(p. 265, BCP).

In this invitation we see the themes both of "letting go", really what fasting means, abstaining

from something, and "taking up," practicing a spiritual discipline. Looking at it in this way, we see Lent is about being present to our relationship with God. What do we need to let go of to grow with God and participate in God's purposes? What must we take up and begin doing? As we let go and take up we may deepen our spiritual life, purify our hearts, and grow in union with God.

The length of Lent is significant then; as R. Lobbs III articulates, "Lent is long and is intentionally so long that it must be kept by ordered self-control, instead of impulsive actions." What a gift it is to have these special weeks to be intentional – not just for Lent, but to take into our daily lives for the rest of the year. **It's all about relationship.**



### Ash Wednesday Schedule

- 7:30 a.m. Eucharist  
"Ashes to GO"  
(Center St.)
- 9 a.m. Morning Prayer
- 12:15 p.m. Eucharist
- 4:30 p.m. "Ashes to GO"  
(Center St.)
- 7. p.m. Ash Wednesday Choral  
Eucharist

## Thoughts about The Legacy Society and Bequests to Trinity Episcopal Cathedral

by Pat Sullivan

Many of you don't know me; I'm a fairly new member who joined in the midst of the Pandemic. I can tell you, however, that Trinity was here for me before my husband died unexpectedly and has surrounded me with love and support since then. In common terminology, Trinity "has my back" and they'll have yours, too.

I'm not wealthy. Wealth is not necessary when it comes to leaving a donation to Trinity Episcopal Cathedral in your will or trust. It takes a loving heart towards Trinity and pre-planning on your part. Along with the kids, the grandkids and other people that have to be taken care of when you die, Trinity needs to be thought of and it **must be in your will or trust**. Could you bequeath \$100.00? \$1,000? \$10,000 or more? Please believe me when I say that \$100.00 is as valuable as the widow's mite.

If you have questions, please contact Jack Dowling, Advancement Director at [jack@trinitylittlerock.org](mailto:jack@trinitylittlerock.org). He would be happy to help you. Or you can visit [www.trinitylittlerock.org/legacy](http://www.trinitylittlerock.org/legacy).



1884  
*Legacy Society*

*The 1884 Legacy Society is happy to sponsor*

### "Tying Up Loose Ends."

Over five weeks in Lent, we will consider the administrative realities of death: planning a funeral, caring for your financial legacy, and being intentional about your spiritual legacy.

Sunday Mornings beginning February 26  
in Morrison Hall  
from 9:15 a.m. - 10 a.m.



## The Storybook Project wants YOU!

by Denise Chai

The Storybook Project of Arkansas is a simple idea with a big impact. It is a prison outreach program with close ties to the Episcopal Church, with the mission to keep families connected during incarceration through the joy of reading.

By recording inmates reading a book to the children in their lives, we give incarcerated parents an opportunity to be a parent and a positive role model for their children. With a book and a CD which they can play over and over, children are able to hear their loved one's voice and know that they are loved and missed.

Volunteers who have been vetted through the ADC bring crates of new books into the prisons - books that are suitable for toddlers through high-school age-readers.

Approved inmates select a book, and Storybook volunteers record the inmate reading the story to the youngsters in their family. The books and recordings are then packed up and sent to the children.

Chaplains in the Arkansas Department of Corrections support our program because reconnecting inmates with their lives outside the prison helps to restore relationships and increases the chance of success after release.

For volunteers, facilitating this very special connection is a blessing in more ways than we can express. The Storybook Project is seeking volunteers to visit the prisons with us. Please contact Denise Chai (501-590-0501), email [storybookprojectar@gmail.com](mailto:storybookprojectar@gmail.com), or check out the website ([storybookprojectofarkansas.org](http://storybookprojectofarkansas.org)) or Facebook page if you are interested in learning more.



*At a recent EYCollab youth helped assemble materials, including a book and a CD, for the Storybook Project.*

*"I have to admit this book reading is one of the most heartfelt things anyone can do for us. It allows us to not only share with our kids but show we love and are thinking of them. Thank God for the Storybook Project." – Byron*

### The Message

A newsletter about life at Trinity Episcopal Cathedral. Send correspondence & address corrections to:

The Message, 310 West 17th Street, Little Rock, AR 72206

Tel. 501-372-0294 Fax: 501-372-0416 email [info@trinitylittlerock.org](mailto:info@trinitylittlerock.org) [www.trinitylittlerock.org](http://www.trinitylittlerock.org)

## LENT AT HOME

by Emma Mitchell

Like in Advent, Lent is a time when our liturgical calendar feels out of step with the world around us. While we're putting ashes on our forehead, reading about desert wanderings, and preparing for Jesus' journey to the cross, all around us flowers are blooming, baby birds are chirping, and we are packing for long-awaited spring break trips!

What is there in Lent for young people? How is this season of preparation a time where we can learn and grow together? Here are some ideas to focus on for each aspect of this season:

### PRAYER

Sometimes something is so routine, we actually forget to do it. Prayer is one of those things. Of course we pray together! But when is the last time you sat together and shared your hopes, concerns, joys, and worries with one another in prayer? Consider adding in prayer time together with your family during this Lenten season (on the drive to school, during a meal, or at bedtime).

#### A Lenten Prayer

Lord, you are always near. Be with us in times of joy and times of anxiety. Today, we pray especially for \_\_\_\_\_.  
Receive all of our prayers with your unending love and grace. Amen.



### FASTING

While giving up certain foods or mealtimes has often been used as a spiritual practice throughout history, it can be tricky to know how to enact this practice in our modern lives. This Lent, consider giving something up collectively as a family (perhaps screen time) or adding something in (a daily walk together).

#### A Simple Prayer for Fasting

Lord, you know our needs better than we do. Be with us as we \_\_\_\_\_ (Lenten activity of choice) and help us to feel your presence in all that we do together. Amen.



### ALMS GIVING

"Alms" comes from a Greek word meaning "mercy". When we give alms, we are showing mercy to others in a very tangible way. During Lent, consider setting up a mite box in your home. You can make your own or pick one up in the back of the church on a Sunday. Regularly during the season, encourage kids to place spare change into the box. At the end of Lent, they can choose where they would like to donate the money they have collected.

#### A Simple Prayer for Alms giving

Lord, we are grateful for the blessings of this life. We give thanks for the ability to share those blessings with others in our community. Amen.





# and Youth



## Mardi Gras/Shrove Tuesday

GUMBO COOK-OFF & PANCAKE SUPPER

**Tuesday, February 21, 5:30 to 7 p.m.  
Chancellors' Hall**

**Come enjoy food, fellowship and fun.  
Face painting by the youth group  
Event will be followed by the  
burning of the palms**

**Contact Dawn Howe  
([dawn@trinitylittlerock.org](mailto:dawn@trinitylittlerock.org)) if you would  
like to volunteer, or to enter a group for the  
gumbo cook-off.**

### UPCOMING DATES

- February 19  
Final Epiphany EYCollab  
(4:00 - 6:00 p.m.)
- February 21  
Mardi Gras Celebration @ Trinity  
(5:30 p.m. - 7:00 p.m.)
- February 22  
Ash Wednesday
- February 26  
Convocational Youth "Lent Party"  
@ St. Margaret's  
(4:00-6:00 pm)
- March 1  
Koinonia Dinner & Eucharist  
(5:30 pm)
- March 3-4  
Youth Confirmation Overnight  
@ Camp Mitchell
- March 15  
Koinonia Dinner & Eucharist  
(5:30- 6:30 p.m.)
- April 1:  
Palm Saturday Family Event  
(10:00 a.m. - 12:00 p.m.)

Central AR Youth  
Lent Party @ St. Margaret's  
SUNDAY, FEBRUARY 26  
4:00-6:00PM

Soup and **board games**  
& exploring the AR House of Prayer

## PALM SATURDAY Family Event

**Saturday, April 1  
10:00 am**

Join us as we explore the  
journey of Jesus to the  
cross together!

## New Offering for Children at Camp Mitchell



Do you have a kiddo interested in trying camp for the first time? A seasoned veteran who just can't get enough camp? Get them signed up for Wild Sprouts, a weekend camp for 1st-5th graders March 24-26, 2023 at Camp Mitchell. This camp session will have a special emphasis on getting to know camp and making lifelong connections with nature. If you have any questions or concerns, please feel free to email [Larnie@campmitchell.org](mailto:Larnie@campmitchell.org)! Registration can be found at <https://bit.ly/wildsprouts>

 <b>CAMP MITCHELL</b>  Summer Camp 2023 Schedule	
<b>Speciality Camp</b> <b>June 11-16</b> (Exciting New Partnership Pending!)	<b>Senior High Camp</b> <b>June 18-23</b> Completed 9th-12th grade
<b>Primary Camp</b> <b>June 25-29</b> Completed 1st-3rd grade	<b>Somewhere Over Camp</b> <b>June 30-July 2</b> All Ages Retreat for LGBTQ+ Youth, Families, and Friends
<b>Middler Camp</b> <b>July 9-14</b> Completed 4th-5th grade	<b>Dick Johnston Children's Camp</b> <b>July 16-21</b> Speciality Camp for children with a current or formally incarcerated parent or guardian
<b>Robert R. Brown Camp</b> <b>July 23-27</b> Speciality Camp for Adults with Physical and Mental Disabilities 18+	<b>Junior High Camp</b> <b>July 30-August 4</b> Completed 6th-8th grade
<b>Campamento Familiar</b> <b>August 4-6</b> (Spanish-Speaking Family Camp open to all!)	<b>Ada Valley View Folk Society Summer Jamboree</b> <b>August 11-12</b> Join us for an End of Summer Celebration and Camp Clean-up!



## From the Choir Pews

by Dr. Colin MacKnight

As it is the primary penitential season of the church year, I aim to make Lent markedly different from other liturgical seasons. One way I do this is by programming more plainsong. Until the ninth century, plainsong (also referred to as plainchant and Gregorian chant) was the exclusive form of Western church music. (If you're uncertain what plainsong is, think of "O come, O come, Emmanuel".) Plainsong is a simpler, more stripped-down type of music, so it lends itself to the seriousness of Lent. This season, the congregation will sing the Kyrie, Sanctus, and Agnus Dei to plainsong, and the choir will chant the psalms to plainsong rather than the usual Anglican chant. Singing plainsong might feel unfamiliar, particularly because it is not metric, but do not be deterred! The lack of meter makes this type of music very speech-like and intuitive. I encourage everyone to fully participate in this beautiful body of music.

Another difference in Lent will be how I use the organ; the voluntaries will be more austere and subdued, you'll hear much less – or maybe even no – back trumpets, and most obviously, I give up liturgical improvisation, choosing instead to leave periods of silence.

This is not at all to say that our liturgical music will be any less interesting or ambitious. Indeed, March 12, the final day of James O'Donnell's conducting residency at Trinity, will be an incredible musical event for Trinity (while remaining completely appropriate for Lent). James O'Donnell is organ professor at Yale University and was Organist and Master of the Choristers of Westminster Abbey from 2000 through Christmas of 2022 (just a few months ago), where he directed the music for all the important royal occasions held at the Abbey for the last two decades, including the marriage of Prince William and Princess Kate and Queen Elizabeth II's state funeral. During his residency, James will lead choir rehearsals on Thursday, March 9 and Saturday, March 11, conduct eucharist and evensong on March 12, and will present a lecture on March 10 at 7 pm as part of Trinity's *Insights* lecture series.

And speaking of evensong, are you still discerning this year's Lenten discipline? If so, attending evensongs could be a great Lenten practice – a way to deepen one's faith, set aside meditative time, and hear beautiful music, scripture, and prayers. During Lent, Evensong will conclude with Holy Eucharist, Rite I.

## James O'Donnell IN RESIDENCE

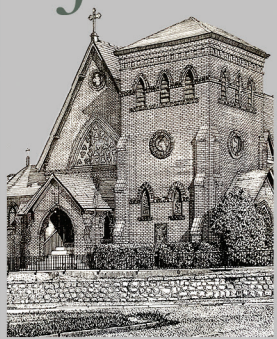

**March 10th at 7 pm**  
**Lecture with James O'Donnell**  
**Free reception to follow**

**5:30 pre-lecture wine**  
**reception with Mr. O'Donnell**  
**and reserved priority seating**  
**during the lecture for \$150**

**March 12**  
**James O'Donnell Conducts**  
**Choral Eucharist at 10:30 am**  
**Choral Evensong at 4 pm**  
**(reception to follow**  
**Evensong)**

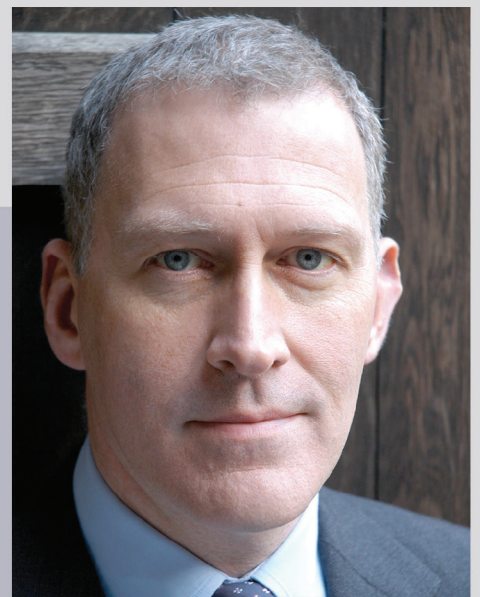

Organ Professor at Yale  
University and former  
Organist and Master  
of the Choristers at  
Westminster Abbey



scan for more  
details and tickets  
to pre-lecture  
reception

## No Bats in our Belfry

by Sandy Miller Hays

Trinity's bell tower underwent a thorough sprucing-up on Saturday, Jan. 28, when members of the Trinity Cathedral Ringing Society gathered to refresh every part of the tower, from the belfry to the baseboards.

Ropes were freshened and secured, windows and woodwork were wiped and polished, floors and carpet were cleaned, and vacuums were vigorously deployed from the highest peaks right down to the ringing chamber floorboards. Even Hank the Stuffed Bat, who keeps a shiny eye on the ropes when all is still, got a friendly swipe. It's no exaggeration to say the Trinity bell tower is now sparkling its brightest in years.

The intrepid tower ringers who accomplished this transformation were Mike Parker, William Hronas, Dick Dearnley, Maggie Dearnley, Scott Stricker, Porter Brownlee, Kay Shurgar, Julie Keller, Mary Wilson, and Bob Barnes.

Now it can be said that Trinity's impressive tower of eight massive bells is not only the most tuneful in town, but also the cleanest.

As always, the Trinity bell ringers love to have folks stop by to watch their efforts, so all are welcome to come see the ringing for themselves every Sunday from 10 to 10:30 a.m.



*Dick and William roping the wheel; Scott polishing the bells; Mary, Bob, Kay, and Maggie pose at the ropes; Kay cleaning the stained glass.*



## A short series about Trinity's Bells

by S. Porter Brownlee

### Part V

Now fully understanding the physics of differing sizes of bells and their similarity to pendulums and having touched on Henry VIII's (possible) desire that his bells be rung differently, let's see how that became possible.

For argument's sake, let's proceed on the premise (not at all historically certain) that Henry wanted his bells rung in an orderly fashion. Let's further assume that the initial desire was that they ring in a descending scale, high notes to low notes. In the case of bells, that would be those smaller, lighter (and more quickly ringing) bells sounding before the bigger, heavier (and more slowly ringing) bells. In order to continuously ring this group of bells, maintaining even spaces between their sounding, we're either going to have to slow down those quick bells or speed up the slow bells. Inertia being what it is and most humans not capable of rapidly turning an upwards of a 2-ton weight, the logical thing then would be to slow down the smaller bells.

How might we do that? If we're the British in the 17th century, we might, after extensive experimentation, install a full wheel on our bells' headstocks and install ropes in such a fashion that the bells may be rung in a full 360 degree circle, sounding once (and very loudly) with each rotation. And, by doing so, we could very subtly "hold" the smaller bells at their tops, which is to say, with bell throats facing up, for the fractions of seconds necessary for the slower, big bells to catch up. We might install other devices called "stays" and "sliders" to assist us in holding the bells in this upright position without going "over the top" and taking the rope (and us if we're not careful) through the hole in the ceiling. The whole arrangement might look like Diagram 1.

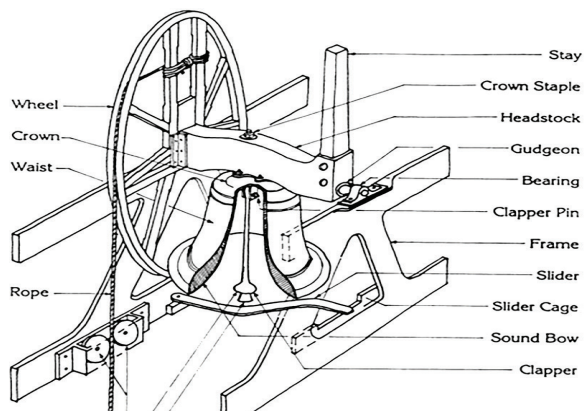

Diagram 1

### Part VI

Again referring to Diagram 1 and ignoring for the moment how this might be accomplished, rotate the bells some 180 degrees such that the "stay" is resting against the "slider," leaving the bell at rest with the mouth facing up. Graphically, this would look like the first section of Diagram 2.

Let's grasp the rope by its "tail" end and then grab the looped rope a little above our head. Just to make things more comfortable, let's add a tufted, woolen section to the rope where we grab it. And, just to make it even more interesting and/or confusing, let's call that woolen section a "sally." (One wonders if the sally's inventor's wife or daughter was the inspiration for the name. Other bell historians swear it was named because it "sallies" to and fro as it's pulled upwards and downwards.)

Now, let's pull on the sally in a smooth downward stroke (see second section of Diagram 2). As we do this, the rope coiled around the wheel pulls the wheel with the bell attached causing it to rotate, the bell itself catching up with the clapper about two thirds of the way around and, if we've done the whole thing right, the bell will continue around a full 360 degrees and reach an equilibrium position again in an upright, vertical position (See fifth section of Diagram 2.)

At this point, our arms would be over our head as shown in the diagram. Assuming we then pull again smoothly, the bell would rotate in the opposite direction 360 degrees coming to rest in its original position. The first pull, with our hands on the sally, is called the "hand stroke," and the opposing stroke, beginning with our hands over our head, the "back stroke." At either end of the bell's swing, we could if we chose, "stand" the bell with the stay resting against the slider, and it is in that position that we leave the bells between sessions.

This entire sequence is reflected in Diagram 2.

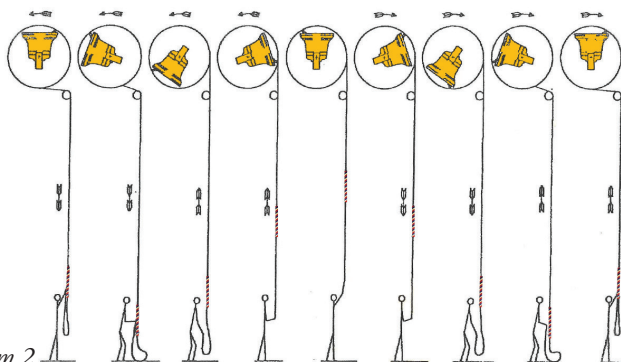

Diagram 2

## Trinity Cathedral Staff

### Dean and Rector

The Very Rev. Amy  
Dafler Meaux

### Clergy

The Rev. Deb Cooper  
The Rev. Canon  
Dr. Lisa Corry  
The Rev. Susan Payne

### Lay Staff

Henry Allen  
Kristine Barbaree  
Reta Dean  
Jack Dowling  
Joe Harris  
Mary Penick Hodges  
Dawn Howe  
Dr. Colin MacKnight  
Emma Mitchell  
Ricky Parks

### ECEP

Christy Poindexter

## The Vestry

Senior Warden  
Steve Bethel  
Junior Warden  
Mary Margaret Wippo  
Treasurer  
Grant Wallace  
Clerk  
Melonese Clarke  
Member at Large  
Kelly Wassell

Susan Allen  
Jack Harvey  
Josh Hill  
Christoph Keller  
Grady McCoy, IV  
John Milwee  
Lara Schock  
David Turner  
Marcia Wayland

Chancellor  
Clarke Tucker

## Connect With Us Digitally

Visit our website: [www.trinitylittlerock.org](http://www.trinitylittlerock.org)

Facebook: [facebook.com/TrinityCathedral](https://facebook.com/TrinityCathedral)

Instagram: @trinitylittlerock

YouTube: [www.youtube.com/c/TrinityLittleRock](https://www.youtube.com/c/TrinityLittleRock)

Tag your photos with #trinitylittlerock when you post about the Cathedral to be part of the conversation.

## Save Paper, Go Electronic

This newsletter is available in digital format on our website and by email.

To go paperless and help preserve our resources, email [communications@trinitylittlerock.org](mailto:communications@trinitylittlerock.org).

